

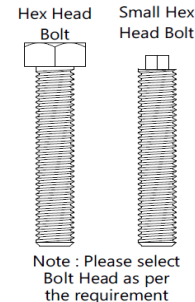

DLK2-a-135-M16x2.0x100-RD	1200	135	50	M16X100	+10	M10/12/16/20/24	From -16 to 90	Red/Yellow powder coating	Textile Machines, CNC Machines, Power Presses, Plastic Injection Moulding Machines, Pressure Die Casting Machine, Printing Machines, Compressors, Grinding Machines and All Types of Heavy Industrial Applications.
DLK2-b-135-M16x2.0x100-RD	1900	135	50	M16X100	+10	M10/12/16/20/24	From -16 to 90	Red/Yellow powder coating	
DLK2-c-135-M16x2.0x100-RD	2600	135	50	M16X100	+10	M10/12/16/20/24	From -16 to 90	Red/Yellow powder coating	

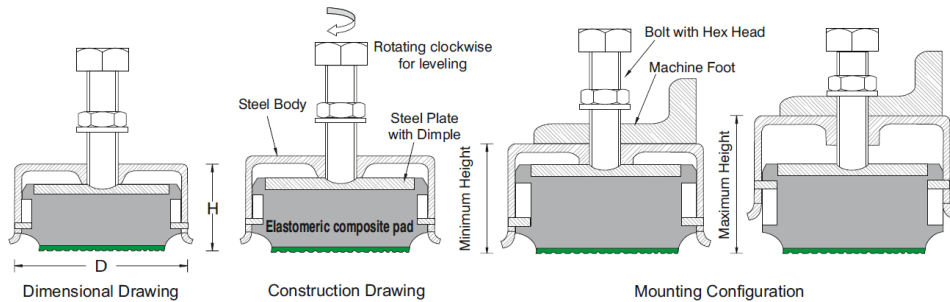

DLK3



Model	Load Capacity Kg/pc	Diameter (D) mm	Height (H) mm	Bolt Size (mm)	Adjustment Range (mm)	Possible Bolts	Temperature Range (°C)	Color	Applications
DLK3-a-195-M20x2.5x150-RD	2900	195	58	M20X150	+12	M10/12/16/20/24	From -16 to 90	Red/Yellow powder coating	Textile Machines, CNC Machines, Power Presses, Plastic Injection Moulding Machines, Pressure Die Casting Machine, Printing Machines, Compressors, Grinding Machines and All Types of Heavy Industrial Applications.
DLK3-b-195-M20x2.5x150-RD	3400	195	58	M20X150	+12	M10/12/16/20/24	From -16 to 90	Red/Yellow powder coating	
DLK3-c-195-M20x2.5x150-RD	4200	195	58	M20X150	+12	M10/12/16/20/24	From -16 to 90	Red/Yellow powder coating	
DLKH2-c-135-M16x2.0x100-RD	2600	135	62	M16X100	+20	M10/12/16/20/24	From -16 to 90	Red/Yellow powder coating	Textile Machines, CNC Machines, Power Presses, Plastic Injection Moulding Machines, Pressure Die Casting Machine, Printing Machines, Compressors, Grinding Machines and All Types of Heavy Industrial Applications.
DLKH3-c-135-M20x2.5x150-RD	4200	195	72	M20X150	+20	M10/12/16/20/24	From -16 to 90	Red/Yellow powder coating	

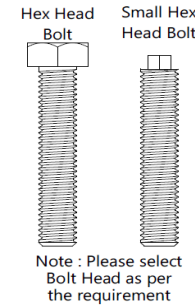
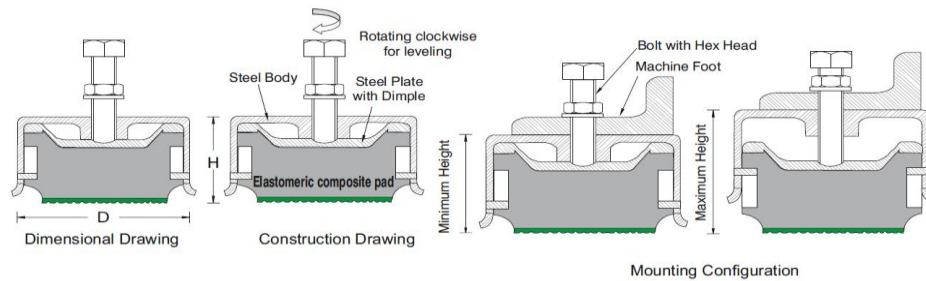

**DLK4**



Model	Load Capacity Kg/pc	Diameter (D) mm	Height (H) mm	Bolt Size (mm)	Adjustment Range (mm)	Possible Bolts	Temperature Range (°C)	Color	Applications
DLK4-a-238-M24x3.0x150-RD	4000	238	78	M24X150	+20	M10/12/16/20/24	From -16 to 90	Red/Yellow powder coating	Textile Machines, CNC Machines, Power Presses, Plastic Injection Moulding Machines, Pressure Die Casting Machine, Printing Machines, Compressors, Grinding Machines and All Types of Heavy Industrial Applications.
DLK4-b-238-M24x3.0x150-RD	5000	238	78	M24X150	+20	M10/12/16/20/24	From -16 to 90	Red/Yellow powder coating	
DLK4-c-238-M24x3.0x150-RD	6000	238	78	M24X150	+20	M10/12/16/20/24	From -16 to 90	Red/Yellow powder coating	